

Rapid Communications

The Rapid Communications section is intended for the accelerated publication of important new results. Manuscripts submitted to this section are given priority in handling in the editorial office and in production. A Rapid Communication may be no longer than 3½ printed pages and must be accompanied by an abstract. Page proofs are sent to authors, but, because of the rapid publication schedule, publication is not delayed for receipt of corrections unless requested by the author.

Direct observation of a two-dimensional gas of spin-polarized atomic hydrogen

L. Pollack, S. Buchman, Y. M. Xiao, H. F. Hess, G. P. Kochanski, and T. J. Greytak

Department of Physics and Center for Material Science and Engineering, Massachusetts Institute of Technology, Cambridge, Massachusetts 02139

(Received 14 April 1986)

We have used NMR to observe the two-dimensional gas of atomic hydrogen adsorbed on a fritted glass "sponge" covered with superfluid ^4He . Measurements were made at a magnetic field of 7 T and at temperatures down to 0.080 K for a ^4He surface and to 0.060 K for a ^3He - ^4He substrate. The temperature dependence of the resonant frequency agrees with Anderson's multiple-residency model. On the ^4He surface the adsorbed hydrogen is first detected at 0.095 K and has a frequency shift of $-21.64(40)$ kHz with respect to the bulk adsorption line, corresponding to a zero-field wall shift of $-43.0(8)$ kHz.

Atomic hydrogen can be stabilized by spin polarization at low temperatures and high magnetic fields. Extensive work in the past few years has led to a detailed understanding of the bulk properties of the resulting gas.¹ Attention is now turning to the submonolayer film of polarized atomic hydrogen that is adsorbed on the liquid-helium-coated walls used to contain the bulk gas. Recombination of the hydrogen within this film limits the bulk densities which can be obtained at the lowest temperatures. In addition, the film itself manifests interesting physical phenomena. A Kosterlitz-Thouless transition has been predicted at high surface densities.² At lower densities surface spin waves may occur.³

Our current understanding of the behavior of the hydrogen surface films comes primarily from indirect means: Measurements of bulk behavior are interpreted in terms of surface processes by using a calculated adsorption isotherm and assuming equilibrium between the two populations. The sole exception is a recent ESR study of spin-polarized hydrogen by Reynolds *et al.*⁴ in which the signal from the surface atoms was shifted from the bulk atomic signal by the electron dipole-dipole interactions between adsorbed hydrogen atoms. We present here results of a series of experiments in which a pulsed NMR technique is used to study the surface and bulk atoms. In these experiments it is the wall shift⁵ of the zero-field hyperfine splitting which allows the two different populations to be studied separately.

Molecular hydrogen is dissociated in a liquid nitrogen temperature discharge. The atomic hydrogen is cooled by a dilution refrigerator and electron spin polarized as it flows into the experimental cell at the center of a superconducting magnet. The flux to the cell, determined by

measuring the recombination heat, is about 5×10^{13} atoms/sec and a typical bulk density is 10^{15} atoms/cm³ at 0.300 K. The cell contains the open-ended loop-gap NMR resonator shown in Fig. 1. The lower half of the volume inside the resonator is filled with a piece of fritted glass "sponge" of characteristic pore size 10 μm and with an area-to-volume ratio of 1000 cm⁻¹.

NMR is used to induce transitions between the two lowest hyperfine states of atomic hydrogen, $|a\rangle$ and $|b\rangle$.¹ The resonant frequency will be denoted by ν_{ab} . The sample is studied with a 1-GHz homodyne spectrometer. Its 30-K noise temperature is determined by the low temperature preamplifier. A fully polarized sample of 2×10^{11} atoms would produce a signal equal to the noise with a

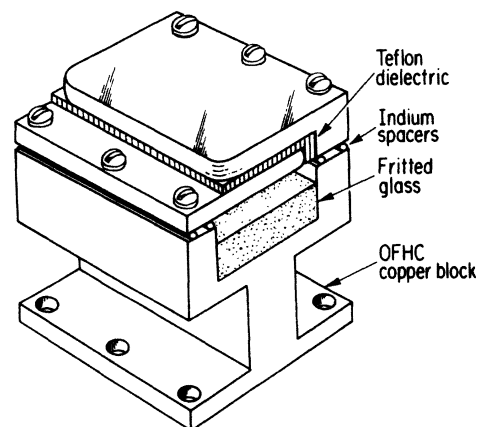

FIG. 1. A schematic diagram of the NMR resonator.

bandwidth of 1 Hz. The magnetic field corresponding to the resonant frequency of the cavity ranges from 6.5 to 6.8 T, depending on the amount of helium condensed in the gap of the resonator. The inhomogeneity of the superconducting magnet was measured to be about 0.5 G over the dimensions of the sponge, and 1.0 G over the resonator.

Data were taken with substrates of ^4He and ^3He - ^4He mixtures and are displayed in Fig. 2. For the ^4He substrate we observe a sharp decrease in the resonant frequency at about 0.095 K as atoms are adsorbed on the surface. A free induction decay signal taken at 0.085 K is shown in Fig. 3. When 25% ^3He is added to the film, however, ν_{ab} remains constant down to the lowest attainable temperature (0.060 K). The linewidth is determined by a Fourier transform of the free induction decay. The resulting width of the bulk line is 4 kHz as expected from an inhomogeneous magnetic field broadening. The surface line is observed to be broader than the bulk line.

A hydrogen atom from the bulk diffuses into the sponge, has collisions with the walls, and eventually sticks to the surface for an average time which increases exponentially with the inverse of the temperature. Nuclear polarization can be determined from the phase of the bulk free induction decay signal: When nuclear polarization occurs due to selective recombination, the signal undergoes a phase change of π radians. The phase of the surface signal demonstrates that the adsorbed atoms are also nuclear polarized in the $|b\rangle$ state. In the absence of spin relaxation by magnetic impurities, recombination would be dominated by surface two- and three-body processes which are not very fast at surface densities on the order of 10^{11} cm^{-2} (Ref. 6). Under these conditions, atomic lifetimes would be on the order of a minute. In contrast, the lifetime of the hydrogen atoms is of the order of 0.1 sec at 0.08 K. The anomalously short lifetime suggests the presence of magnetic impurities inside the sponge. These impurities cause the nuclei to relax from the $|b\rangle$ to the $|a\rangle$ state, allowing

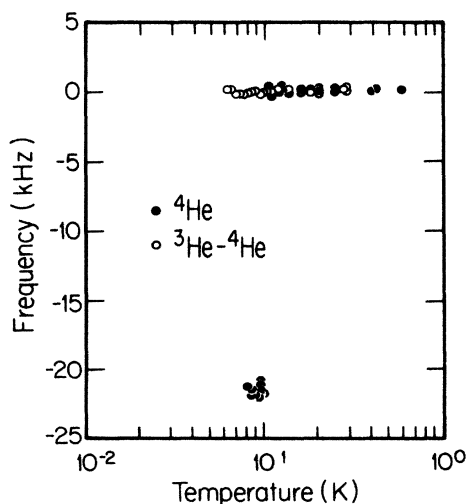

FIG. 2. The measured resonant frequency as a function of temperature for both ^4He and ^3He - ^4He -mixture substrates. The zero of frequency is arbitrarily placed at the bulk value to reflect the high field wall shift.

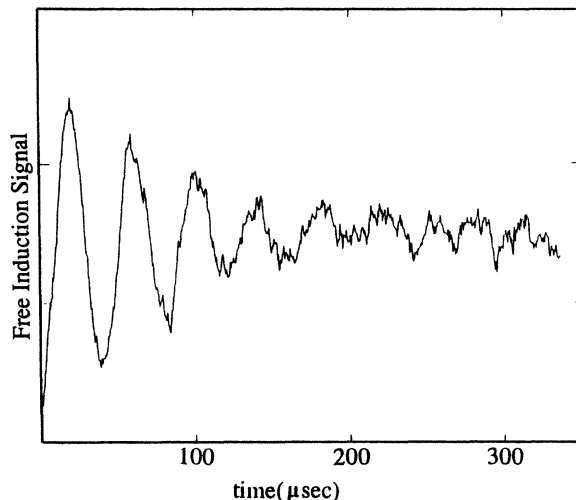

FIG. 3. The free induction decay signal from atoms adsorbed to the ^4He -coated surface at $T = 0.085$ K. This trace is an average of 6400 decays.

the faster two-body-recombination processes to operate. Calculations based on these measurements show that the hydrogen fills only about 25% of the sponge. Even under such unfavorable conditions, however, we were able to detect the surface resonance signal at low temperatures.

The transition frequency, ν_{ab} for hydrogen adsorbed on the surface should be smaller than that for the atoms in the bulk because the hyperfine frequency is decreased by the van der Waals interaction that is responsible for binding the atoms to the surface. A model developed by Anderson and Weiss⁷ can be applied to such a system with two distinct resonant frequencies. The form of the absorption spectrum depends on the ratio of the wall shift [$\nu_{ab}(\text{bulk}) - \nu_{ab}(\text{surface})$] to the transition rate between surface and bulk. We expect to see a single resonance line with a temperature-dependent frequency as shown in Fig. 4. Our surface line appeared at a frequency 21.64(40) kHz below the bulk line, which yields a measured value of 43.0(8) kHz for the hyperfine wall shift for hydrogen on ^4He at zero field. A previous value for this parameter, 49(1) kHz, was reported by Morrow and co-workers^{8,9} by extrapolating frequency shifts at higher temperatures where the fraction of time spent on the surface is never greater than 10^{-3} . Above 0.125 K the frequency shift of the bulk line as a function of temperature is masked by the signal from the atoms outside of the sponge. The model refers only to atoms inside the sponge while the ratio of occupied volume in the sponge to that outside is only about $\frac{1}{100}$. According to the model, the signal from the sponge is too broad to be detectable between 0.125 and 0.095 K. Below 0.095 K, the line is at the wall-shifted frequency in agreement with the temperature dependence of the model. With signal averaging we can observe about 5×10^{12} adsorbed atoms. The lowest attainable sponge temperature was 0.060 K under the present conditions. For a ^3He - ^4He substrate, the resonant frequency is temperature independent for our conditions because both the binding energy and the sticking coefficient are reduced. For a saturated

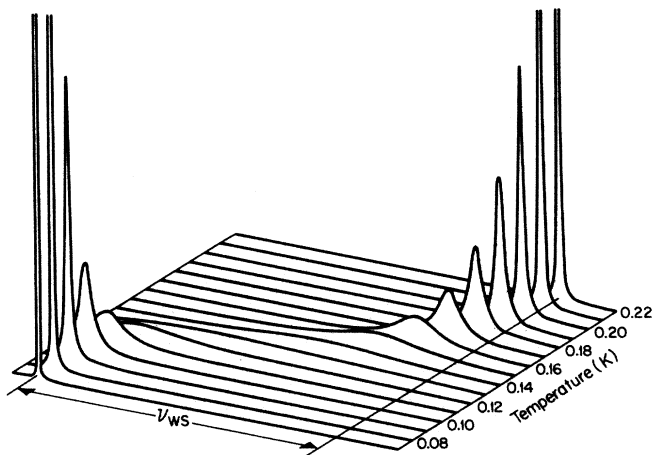

FIG. 4. The temperature dependence of a resonance line in a two-frequency system predicted by Ref. 7 under the conditions described in the text. The frequency difference between the two lines is the wall shift, ν_{ws} .

surface layer of ^3He , $E_b = 0.34$ K (Ref. 10) and $s = 0.016$ (Ref. 8). For these values the model predicts that the shift to the surface frequency will occur at 0.045 K.

The surface resonance line should be narrower than the bulk line if the broadening were solely due to magnetic-field inhomogeneity. However, the Fourier transform of the surface free induction decay shows an average surface linewidth of 6 kHz, whereas the linewidth should be only 2

kHz from magnetic-field inhomogeneity. We tentatively attribute the additional broadening by 4 kHz to the anisotropy of the wall shift, due to the random orientation of the surfaces of the pores in the sponge with respect to the magnetic field. Such a process has been modeled by Kazanskii, Pariiskii, Aleksandrov, and Zhidomirov,¹¹ who replace the effect of binding by a uniform electric field normal to the surface. In the presence of this field, the electron's wave function is no longer spherically symmetric and the hyperfine interaction is anisotropic. The linewidth calculated from this model is only 1.2 kHz; however, this model also underestimates the anisotropy for H on substrates of Vycor glass¹² and of silica gel¹¹ by a comparable factor. The broadening of the line due to the dipolar field of neighboring electrons is small compared to the field inhomogeneity (< 1 kHz).

In conclusion, we have shown that NMR can be used to detect atomic hydrogen adsorbed on a liquid ^4He surface. We have determined both the frequency and width of the surface absorption line. This technique, used together with better characterized substrates, should make it possible to look for surface spin waves and phase transitions in two-dimensional spin-polarized hydrogen.

We would like to thank D. Kleppner for discussions about the work and the manuscript, and T. Steiger for assistance in data taking. This work was supported by the National Science Foundation under Grant No. DMR-8418718. One of us (G.P.K.) would like to acknowledge the support of AT&T Bell Laboratories.

- ¹T. J. Greytak and D. Kleppner, in *New Trends in Atomic Physics*, edited by G. Greenberg and R. Stora (North-Holland, Amsterdam, 1984), p. 1125.
- ²D. O. Edwards and I. B. Mantz, *J. Phys. (Paris) Colloq.* **41**, C7-257 (1980).
- ³E. P. Bashkin, *Pis'ma Zh. Eksp. Teor. Fiz.* **40**, 383 (1984) [*JETP Lett.* **40**, 1197 (1985)]; J. M. V. A. Koelman, H. J. M. F. Noteborn, L. P. H. deGoey, and B. J. Verhaar, *Phys. Rev. B* **32**, 7195 (1985).
- ⁴M. W. Reynolds, I. Shinkoda, W. N. Hardy, A. J. Berlinsky, F. Bridges, and B. W. Statt, *Phys. Rev. B* **31**, 7503 (1985).
- ⁵R. Jochemsen, M. Morrow, A. J. Berlinsky, and W. N. Hardy, *Phys. Rev. Lett.* **47**, 852 (1981).
- ⁶H. F. Hess, D. A. Bell, G. P. Kochanski, D. Kleppner, and T. J. Greytak, *Phys. Rev. Lett.* **52**, 1520 (1984).

- ⁷P. W. Anderson and P. R. Weiss, *J. Phys. Soc. Jpn.* **9**, 316 (1954).
- ⁸M. R. Morrow, Ph.D. thesis, University of British Columbia, 1983 (unpublished).
- ⁹W. N. Hardy, M. Morrow, R. Jochemsen, and A. J. Berlinsky, *Physica B* **109** & **110**, 1964 (1982).
- ¹⁰D. A. Bell, H. F. Hess, G. P. Kochanski, S. Buchman, L. Pollack, Y. M. Xiao, D. Kleppner, and T. J. Greytak (unpublished).
- ¹¹V. B. Kazanskii, G. B. Pariiskii, I. V. Aleksandrov, and G. M. Zhidomirov, *Fiz. Tverd. Tela (Leningrad)* **5**, 649 (1963) [*Sov. Phys. Solid State* **5**, 473 (1963)].
- ¹²G. L. Millhauser, Ph.D. thesis, Cornell University, 1986 (unpublished); J. Freed (private communication).